

Preparation

Part Number: PT347-76110

Kit Contents

Item #	Quantity Reqd.	Description
1	1	Convenience Net
2	1	Hardware bag

Hardware Bag Contents

Item #	Quantity Reqd.	Description
1	1	RH Bracket
2	1	LH Bracket
3	2	Trim Panel Covers

Additional Items Required For Installation

Item #	Quantity Reqd.	Description
1	N/A	

Conflicts

None

Recommended Tools

Personal & Vehicle Protection	Notes
Special Tools	Notes
Installation Tools	Notes
Trim Panel Removal Tool	
Socket	¼ drive 10 mm
Socket Driver	¼ drive
Special Chemicals	Notes

General Applicability

All

Recommended Sequence of Application

Item #	Accessory







*Mandatory

NOTE: Part number of this accessory may not be the same as the part number shown.

Vehicle Service Parts (may be required for reassembly)

Item #	Quantity Reqd.	Description
1		

Legend

	STOP: Damage to the vehicle may occur. Do not proceed until process has been complied with.
	OPERATOR SAFETY: Use caution to avoid risk of injury.
	CAUTION: A process that must be carefully observed in order to reduce the risk of damage to the accessory/vehicle and to ensure a quality installation.
	TOOLS & EQUIPMENT: Used in Figures calls out the specific tools and equipment recommended for this process.
	REVISION MARK: This mark highlights a change in installation with respect to previous issue.
	SAFETY TORQUE: This mark indicates that torque is related to safety.

Procedure

Care must be taken when installing this accessory to ensure damage does not occur to the vehicle. The installation of this accessory should follow approved guidelines to ensure a quality installation.

These guidelines can be found in the "Accessory Installation Practices" document.

This document covers such items as:-

- Vehicle Protection (use of covers and blankets, cleaning chemicals, etc.).
- Safety (eye protection, rechecking torque procedure, etc.).
- Vehicle Disassembly/Reassembly (panel removal, part storage, etc.).
- Electrical Component Disassembly/Reassembly (battery disconnection, connector removal, etc.).

Please see your Toyota dealer for a copy of this document.

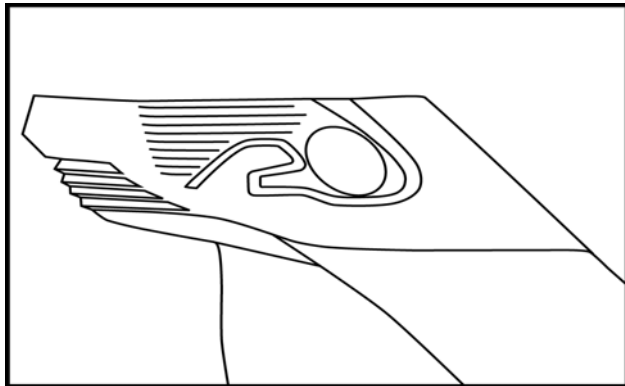

1. Installation of hooks

- (a) Open the rear cargo door and locate the panel shown on the passenger's side of the vehicle.

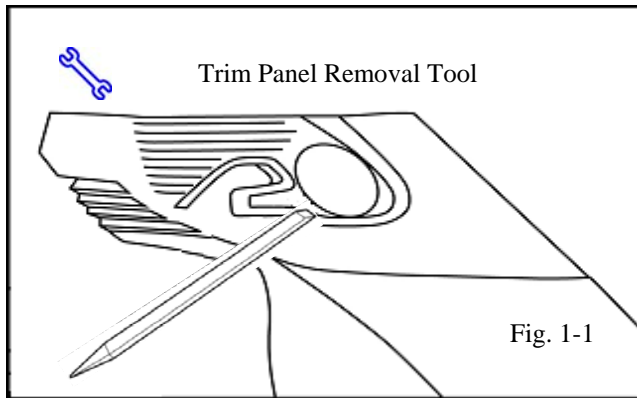

- (b) Remove and discard panel cover with a trim panel removal tool. (Fig. 1-1)

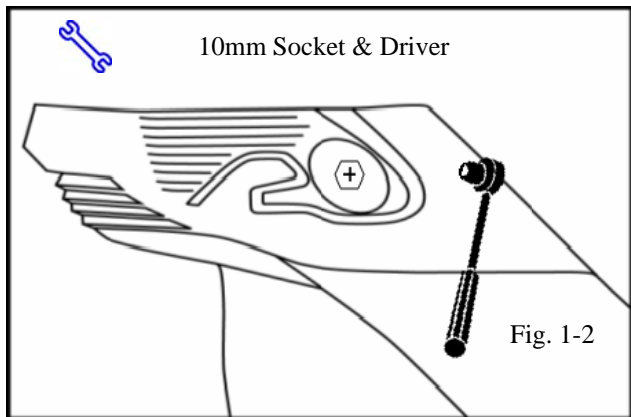

- (c) Remove and retain the screw using a 10mm socket and driver. (Fig. 1-2)

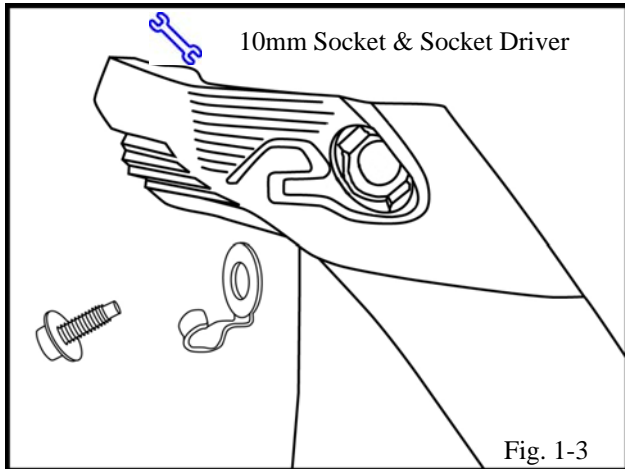

- (d)  Passenger side.
Select RH bracket. Install RH bracket with the screw removed from step 1(c) through the hole of the bracket into the panel recess. (Fig. 1-3)

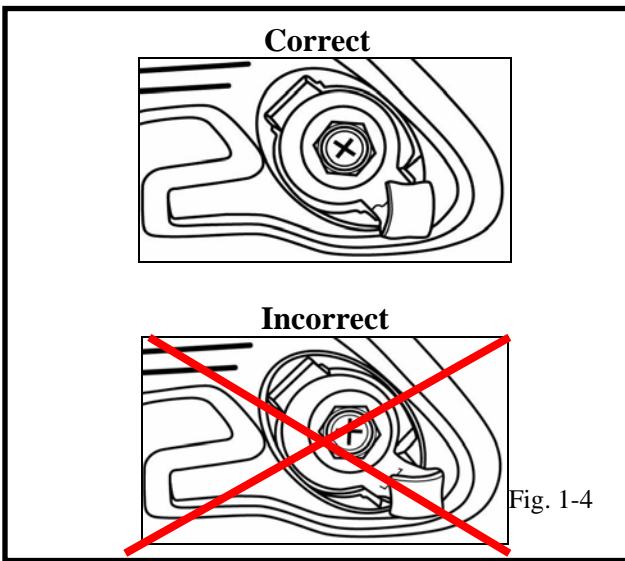

- (e)  Ensure the hook is located on the bottom of the opening. Tighten with a 10mm socket with driver. (Fig. 1-4)

DO NOT OVER-TIGHTEN SCREW

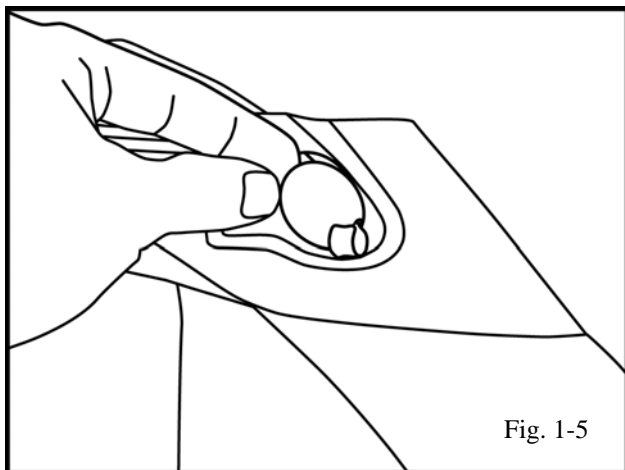

- (f)  Install a trim panel cover over the bracket. (Fig. 1-5)

- (g) Driver side.
Repeat steps 1(b) through 1(f) to install a LH bracket.

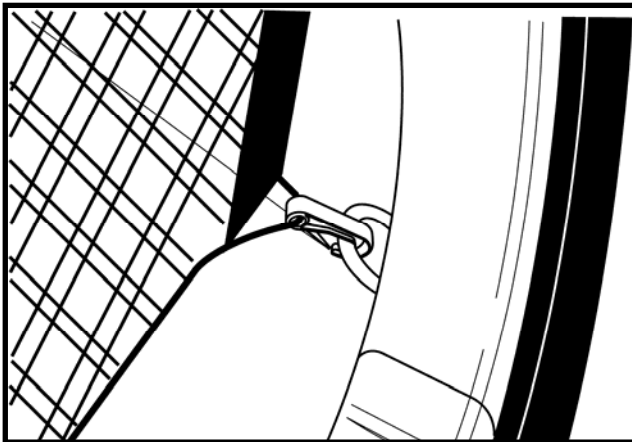

Fig. 2-1

2. Installation of Cargo Net

- (a) Orient the net so the pull-tab is facing towards the rear of the vehicle and install the bottom hook over the passenger side lower D-ring as shown. (Fig. 2-1)

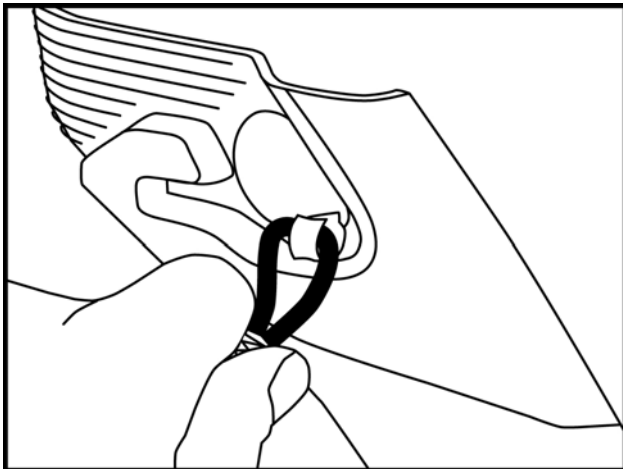

Fig. 2-2

- (b) Install the upper bungee loop over the passenger side hook as shown. (Fig. 2-2)

- (c) Repeat steps 2(a) & 2(b) for the driver side of vehicle.

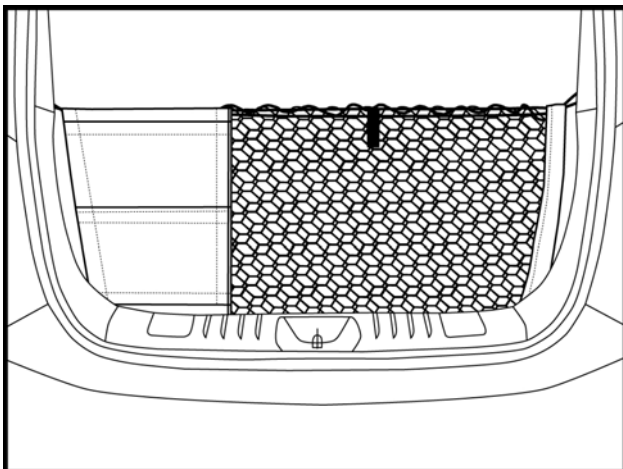

Fig. 2-3

- (d) Completed assembly as shown. (Fig. 2-3)

Checklist - these points **MUST** be checked to ensure a quality installation.

<u>Check:</u>	<u>Look For:</u>
<p><u>Accessory Function Checks</u></p> <p><input type="checkbox"/> Correct orientation of hooks.</p> <p><input type="checkbox"/> Confirm the net is attached properly to the anchor points in the vehicle.</p> <p><input type="checkbox"/> Pull Tab orientation.</p>	<p>Insure hooks are located in the bottom of the recessed opening after the screw is tightened.</p> <p>Make sure the net hooks are attached to the lower D-rings and the loops are attached to the hooks at the top.</p> <p>Make sure the net's plastic pull tab is facing rearward.</p>
<p><u>Vehicle Function Checks</u></p> <p><input type="checkbox"/> Rear cargo door.</p> <p><input type="checkbox"/> <u>Tonneau Cover</u></p>	<p>Rear cargo door should open and close freely without interference from cargo net.</p> <p>Tonneau cover should open and close freely without interference from cargo net or hook.</p>